

User Manual

OPERATING LIGHT NEXUS

OL-01 and OL-02

Serial no



Edition 3.1

September 2024

Manufacturer:

Infimed Spółka z ograniczoną odpowiedzialnością

ul. Kabaty 1
34-300 Żywiec

Polska

WWW.infimed.pl

Tel/fax +48 33 861 40 96

SRN: PL-MF-000015633

NIP 553 251 29 67
REGON 243274947

In accordance with Annex VIII to Regulation (EU) 2017/745 of the European Parliament and of the Council, the lamp has been classified as class I, according to rule 13.

The manufacturer declares that the product complies with the general safety and performance requirements contained in Annex I to Regulation (EU) 2017/745 of the European Parliament and of the Council and the Medical Devices Act.

The manufacturer declares that he is following the conformity assessment procedure set out in Article 52(7) of Regulation 2017/745, after drawing up the technical documentation set out in Annexes II and III of Regulation 2017/745.



Dear Customer!

As a manufacturer, we congratulate you on the right choice and wish you many years of satisfaction with the use of the purchased lamp.

To ensure the longest possible trouble-free service life of the product, please read these instructions carefully and follow all manufacturer's recommendations for proper installation, use and maintenance of the product.

1. Safety.....	4
1.1. General safety remarks	4
1.2. General remarks concerning the safe use of the product.....	4
1.3. Technical parameters	5
1.4. General requirements	9
1.5. Products description.....	9
1.6. Description of the light elements.....	10
1.7. Electromagnetic compatibility	11
2. Transport and start-up	11
2.1. Transport	11
2.2. Unpacking, storage and first start	12
3. Use and operation	13
3.1. Control panel (sample version of the touch panel LCD and membrane keyboard).....	13
3.2. Adjustment by regulation holder (additional option)	17
3.3. Positioning of the light heads depending on the spring arm	18
4. Mains supply and battery charging	20
5. Collision hazard	21
6. Assessment of correct operation	21
7. Defects and faults.....	22
8. Cleaning and disinfecting	22
9. Maintenance and repairs	22
10. Technical inspection and periodical inspection	23
11. Removing of potential problems.....	23
12. Product liquidation.....	24
13. Electromagnetic emissions.....	25
14. Labels.....	27

1. Safety

The product was designed and manufactured in order to ensure the safe use and maintenance of the device. In order to use the lamp safely it is necessary to read, understand and follow the rules set out in this manual.



This marking has been placed on parts and mechanisms whose handling contrary to the guidelines of the instructions may result in a hazard to the safety of the patient or the staff.

Consulting the instruction is absolutely necessary.

1.1. General safety remarks

- It is forbidden to use, maintain and service the lamp in a manner contrary to this user's manual. It may cause damage for which the user will be responsible, and for which the manufacturer is not liable.
- The user has no right to modify or repair the product on his own. Such an attempt will result in the loss of warranty for the product. Repairs may only be performed by a maintenance service or a representative of the manufacturer.
- The optical radiation emitted by this product complies with the exposure limits for reducing the risk of photobiological hazards in IEC 60601-2-41.
- **Any serious incident related to the device must be reported to the manufacturer and the competent authority of the Member State where the user or patient is resident.**

1.2. General remarks concerning the safe use of the product

- This product emits possibly hazardous optical radiation. Do not stare at the light emitted from the surgical luminaire. Eye injury may occur.
- Lamp cannot be used when diaphragm or lens system indicates a failure (unstable mount, crack, etc.). Wrong temperature or change of light parameters can impact on the operation.
- When moving the arms of the lamp you should pay attention to avoid mechanical collisions between arms or lamp heads,
- In order to achieve full range of lighting control, the distance between the operating field and the lamp should be from 0.6 to 1.5 m
- The lamp must be connected to power sources in accordance with the rating plate (source operation indication on the ceiling cover: main - green LED and emergency – orange LED).
- The lamp is not designed to work in potentially dangerous locations (i.e. where is a risk of explosion).

- Do not place other objects on the elements of the lamp, as it may lead to loss of stability of the suspension or threats during an operation.
- Do not store the lamp with discharged batteries.
- If the product is not used for more than a week, the mains switch should be turned off, and after a long period of non-use of the product, the batteries should be recharged – at least once every six months.
- Do not use bleaching compounds, containing active chlorine or oxygen.
- Do not use any compounds containing ingredients which destroy the structure of plastics for the washing of plastic elements.
- The lamp set consisting of two OL-01 light heads can generate irradiance above 1000W / m² (at maximum E_c).
- Use the lowest possible E_c illuminance appropriate for the treatment.
- Avoid overlapping light fields with a high value of illuminance E_c - if the light intensity E_c of one lamp is set to 100%, then in the case of overlapping of the other field, its intensity E_c should be set below 40%.
- If the E_c illuminance of two or more lamps is set to 80% or more, their fields should not overlap.
- The lamp should be placed at a distance of 100 cm from the operating field, in the case of other distances (especially shorter distances) the permissible values of optical radiation power may be exceeded.

Failure to following the above requirements, principally the ones concerning washing and disinfecting will result in a loss of warranty for the product

1.3. Technical parameters

Technical parameters of operating lights Infimed Nexus:	OL-01	OL-02
Light intensity E _c	160 000lx	130 000lx
Light intensity adjustment	5 - 100%	5 - 100%
Color temperature T _c (lights without color temperature adjustment)	4300K (4800K)*	4300K (4800K)*
Color temperature T _c (lights with color temperature adjustment)	3800-4800 (3700-5000K)*	3800-4800K (3700-5000K)*
Light field diameter d ₁₀ at E _c	240-340mm (200-360mm)*	240-340mm (200-360mm)*
Working range without refocusing	600 - 1500mm	600 - 1500mm
Luminous depth (L1+L2) 60% and 20%	800 and 1300mm	800 and 1300mm
Color rendering index [Ra(1-8)]	>95 (>97)*	>95 (>97)*

Red color rendering index [R9]	>94	>94
Irradiance Ee in DRef = 1000 mm	<570W/m ²	<520W/m ²
Maximum irradiance Etotal in DMI = 850 mm	< 690 W/m ²	< 620 W/m ²
Integrated system of endo lighting with adjustable intensity	Green light (white light)*	Green light (white light)*
Temperature of light surface	<40,00°C	<40,00°C
Increase of temperature near doctor's head	<1,00°C	<1,00°C
Power supply	90-250V AC	90-250V AC
Power consumption (+_10%)	110W	80W
Luminary heads voltage	24-28V DC	24-28V DC
Life cycle of the lights	>60 000 hours	>60 000 hours
Class of protection of light head	IP54	IP54
Lifetime	10 years	10 years

The Dref reference point for lamp luminous measurements is DRef = 1000 mm Lamp luminous parameter tolerance +/- 10 %

* - additional versions

Camera Specifications	Description
Image Device	1/2 .8 type Exmor CMOS sensor
Effective Pixels	Approx. 2 millions
Digital Zoom	Min 10x
Optical Zoom	Min 20x
Horizontal Viewing Angle	54.1° to 2.9°
Sync System	Internal
Electronic Shutter	1 /2 to 1/10,000 s, 21 steps
White Balance	Auto
Focus System	Auto
Exposure Control	AE Control: Auto, Manual, Priority (shutter priority and iris priority)
Video Output	
Lens Value	20x Optical Zoom, f=4.7 mm (wide) – 94.0 (tele), f1.6 to f3.5
S/N Ratio More	>50 dB
Signal System	Signal System HD: 1080p/29.97, 1080p/25, 1080i/59.94, 1080i/50, 720p/50, 720p/29.97, 720p/25, SD: NTSC/PAL

For special customers request it is possible to produce the devices with changed parameters not influencing the safety.

Configuration of lights NEXUS OL-01 and OL-02

Single ceiling suspension

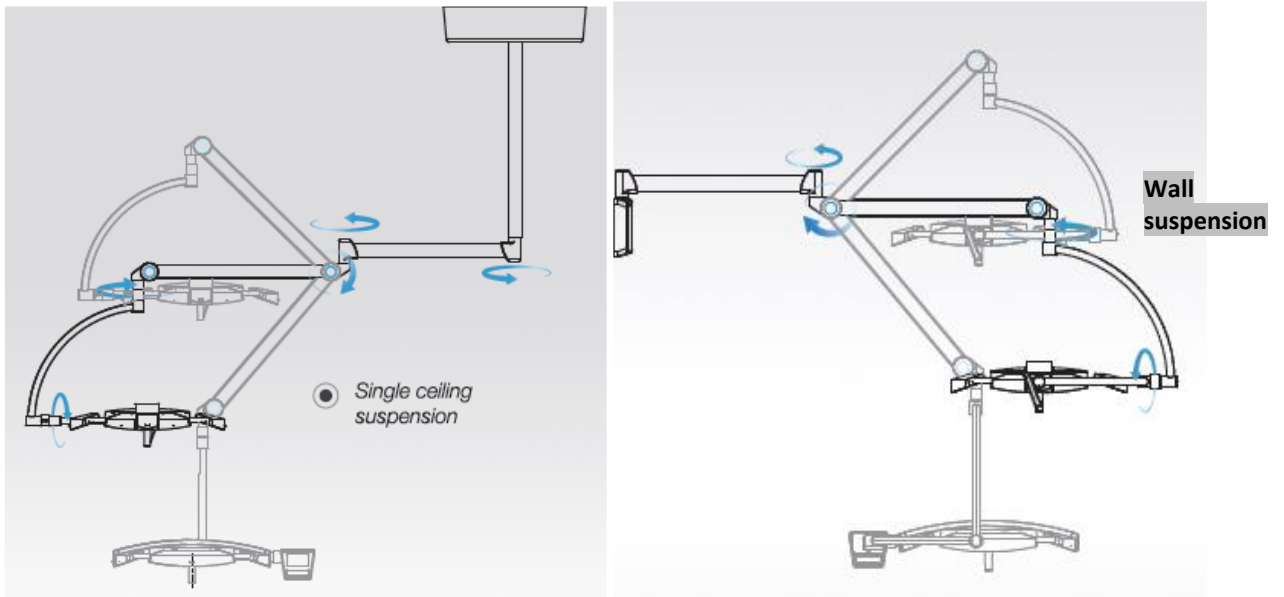

Mobile base and triple ceiling suspension (two arms with rotation $n < 360^\circ$, third one with rotation $n \times 360^\circ$)

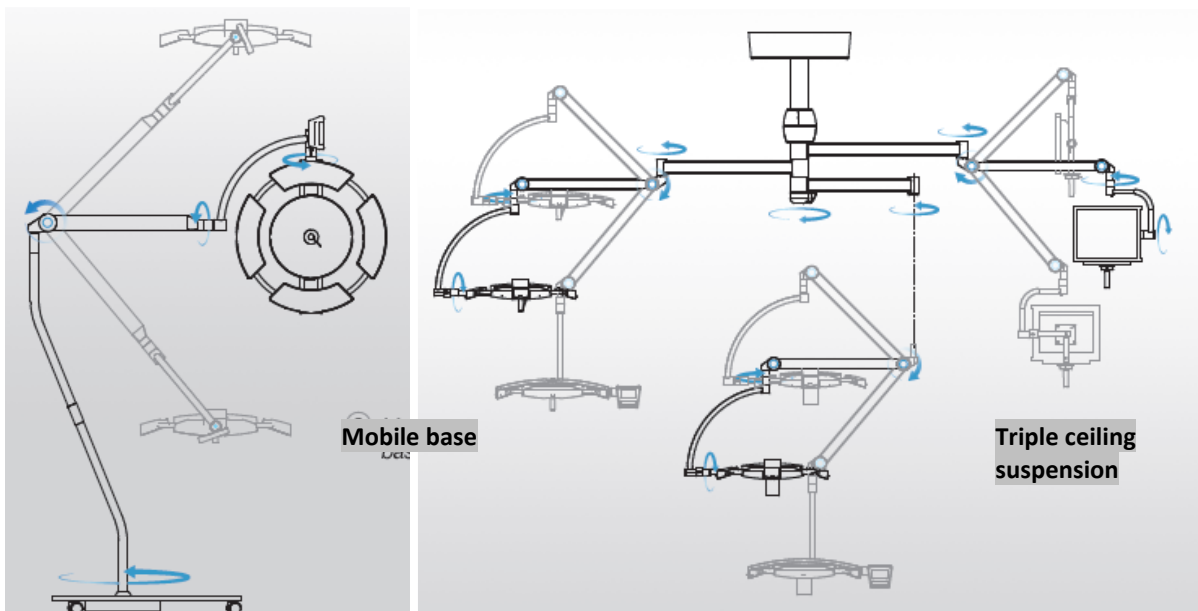

Double ceiling suspension with rotation $n \times 360^\circ$

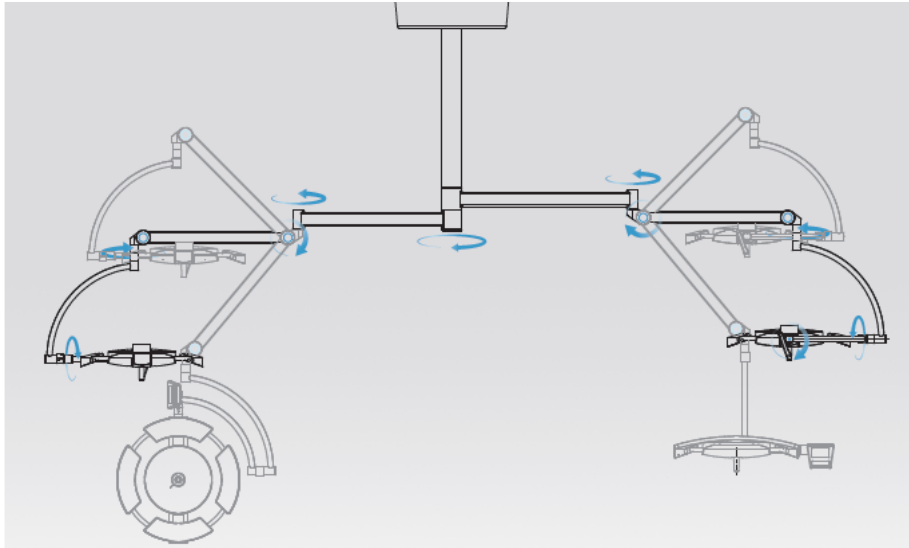

Double ceiling suspension "T" type (two arms with rotation $n < 360^\circ$)

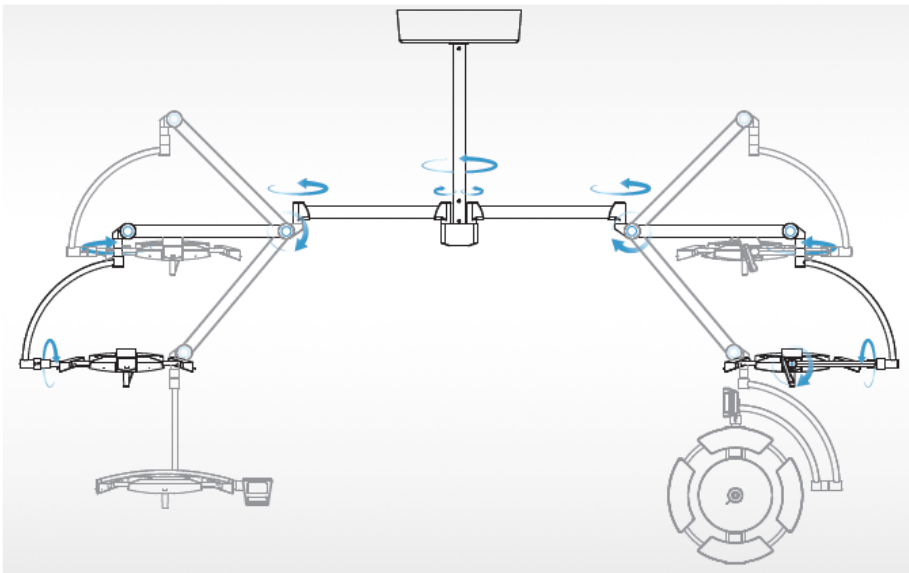

Double ceiling suspension with rotation $n \times 360^\circ$ for rooms with low height

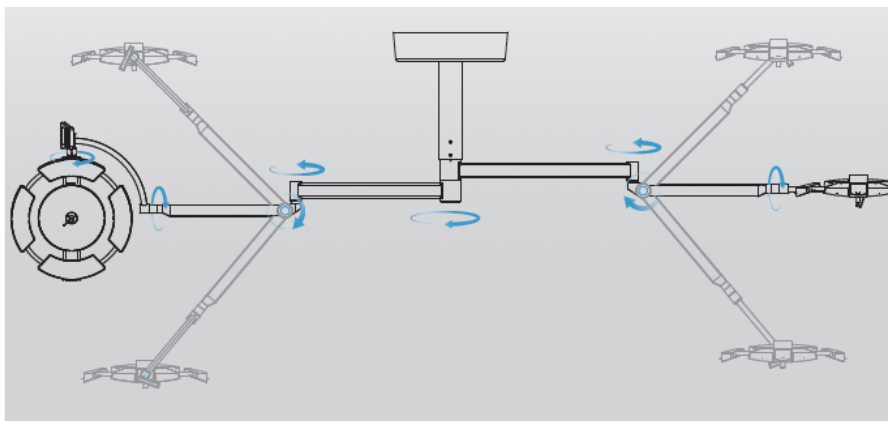

1.4. General requirements

The product should be used, maintained and serviced in accordance with the principles contained in this manual.

The lamp is intended to be installed and used only in closed spaces. **It is forbidden to use, maintain and service the lamp in a manner contrary to this user's manual. It may cause damage for which the user will be responsible, and for which the manufacturer is not liable. Any changes in the lamp's elements contrary to the user's manual, using different equipment than the one offered by the manufacturer may only be allowed with a written permission from the manufacturer. The user must ensure that all the personnel which operates and uses the product knows, understands and applies this user's manual.** Also user is obliged to ensure that the lamp is used only as intended and in appropriate conditions. The user is obliged to guarantee all the necessary means to provide safe and proper function of the product and to prevent any threats to life and limb of himself, his patients and third parties.

1.5. Products description

Operating lights NEXUS OL-01 and OL-02 use LED diodes as light source. They are designed to light operating field during surgical treatments and operations. The most important features are very good, persistent technical parameters, very low temperature radiation or very long working time. Operating lamps OL-01 and OL-02 provide high values of light intensity and color rendering indexes. The parameters of the lamp can be adjusted by means of a sterile handle (optionally with contactless switching of functions), by means of an integrated control panel and by external controllers - the Opera system or a wireless control panel. The control panel allows you to adjust the light intensity, field diameter, adjust the color temperature and work in the endoscopic lighting mode. The control panel can be made optionally with an automatic lighting intensity control system depending on the brightness level of the lamp's surroundings or with a synchronized control of multiple light heads. The little weight of the lamp and used handles make easy setting up and positioning of light head. Leak-proof construction with high degree of protection provided by enclosures, guarantee easy disinfection and maintenance.

Operating lights OL-01 and OL-02 are offered in 3 installations versions: ceiling, wall mounted or mobile. Operating lights OL-01 can be equipped with integrated camera to monitor and record the surgery.

1.6. Description of the light elements

Example of the structure of light heads:

NEXUS OL-01

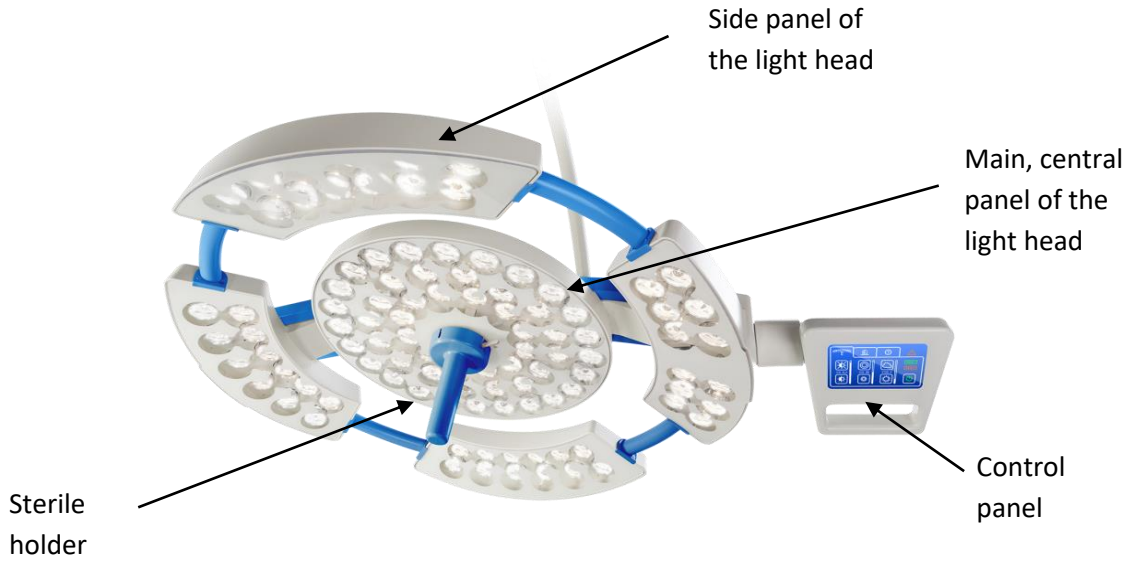

NEXUS OL-02

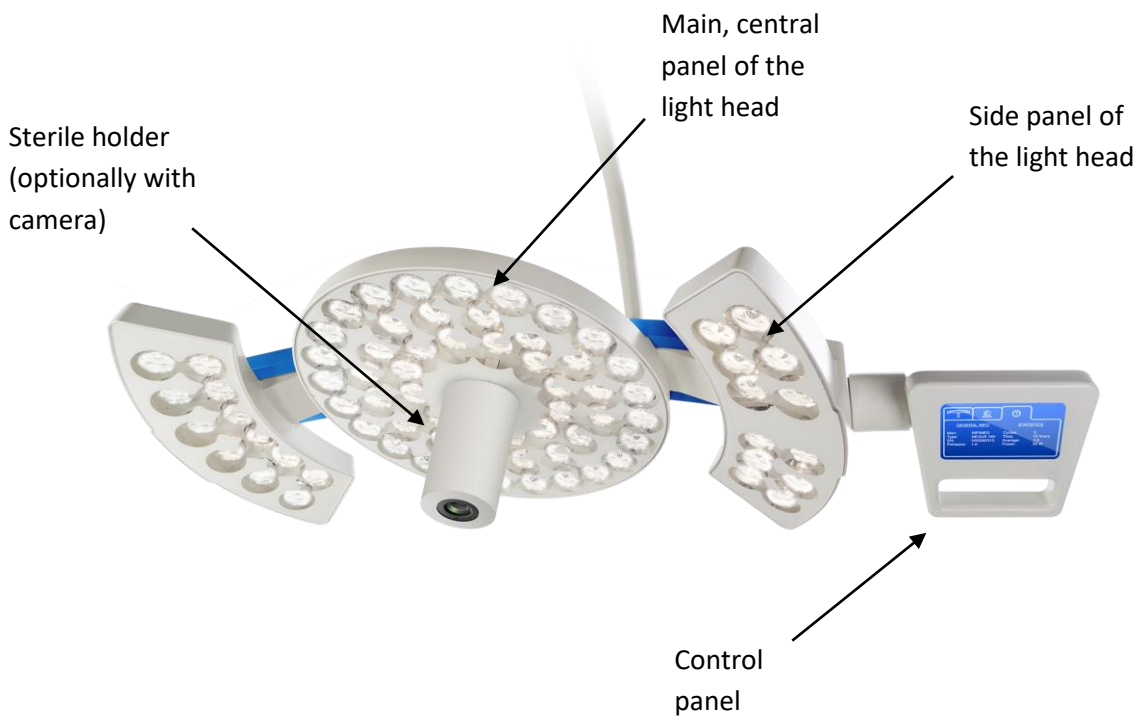

1.7 Electromagnetic compatibility

Medical device: **OL-01 and OL-02** is an electrical device. Electrical devices are a source of electromagnetic radiation and are themselves subject to its influence.

The use of an electrical appliance requires the use of proper precautions related to electromagnetic compatibility.

In tables: *item 7 Characteristics of electromagnetic environment* – there is described electromagnetic environment in which medical device: **OL-01 and OL-02** should be used. Recommendations and warnings which should be followed by the users were also presented.

The use of accessories, accessories, cables, spare parts other than those offered and/or recommended by the manufacturer may result in increased emissions and/or reduced resistance of the product to electromagnetic phenomena in general.

Recommended distances between portable radio-transmitters and the product

Rated maximum output power of transmitter W	150 kHz to 80 MHz	150 kHz to 800 MHz	800 MHz to 2.5 GHz
	$d = 1,2\sqrt{P}$ distance in meters	$d = 1,2\sqrt{P}$ distance in meters	$d = 2,3\sqrt{P}$ distance in meters
0.01	0,1	0,1	0,2
0.1	0,4	0,4	0,7
1	1,2	1,2	2,3
10	4	4	7
100	12	12	23

For transmitters, the maximum output power of which is not specified above, the separation distance should be calculated according to the formulas provided. P is a power in watts (W) according to the declaration of the transmitter manufacturer.

NOTE The above guidelines may not be applicable to all cases. Propagated electromagnetic waves are absorbed and reflected from buildings, objects and people.

2. Transport and start-up

2.1. Transport

The product can be transported by all generally available covered means of transport. During the transportation, the product has to be protected against humidity and dust and immobilized in place. During the transportation, storage and unpacking of the product the temperature should range from -10 to +60°C, and humidity 20-60%. During unpacking of the product the temperature changes may not exceed 8-10°C per hour. The product should not be unpacked before it reaches the temperature of the room where it will be installed. In case of significant temperature differences between the

transport temperature and room temperature where the product will be used, the lamp should be left for a minimum of 12 hours in order to equalize the temperature level. After this period the lamp can be started. Unless the transport packaging is clearly marked otherwise, you may not place the products in layers.

In the case of transporting the lamp in specific conditions (low temperature of surroundings) the method of transporting and securing the product has to be coordinated with the manufacturer.

2.2. Unpacking, storage and first start

The lamp is provided by the manufacturer in a box. Do not unpack the lamp outside of the building.

Preparing the lamp for work should be performed as follows:

- a) Make sure whether the transport packaging was placed for an appropriately long period of time in the room where the lamp will be used.
- b) Open the transport packaging and remove all the materials which protected the lamp during transport
- c) Assembly the system of ceiling plate to the existing ceiling according to the Building Preparation Manual for the Infimed operating and treatment lights.
- d) Install suspension of the lamp, depending on lamp version (installation according to Installation manual on the holder provided by manufacturer)
- e) Install lamp head in the suspension
- f) Connect lamp to power supply system, then connect the power supply system to the mains
- g) Carefully read the user's manual.
- h) Check mechanical systems of the lamp

In case the lamp is not fully operational, that is, the parameters are not in accordance with the description in the user's manual, its use is not allowed. You should contact the supplier, maintenance service or the manufacturer. The use of a defective product may cause damage for which the user will be responsible, and for which the manufacturer is not responsible.

If the product will not be used for a longer period of time, it should be stored in the following environmental conditions:

- temperature: 25°C (77°F) \pm 10°C (18°F)

- humidity: $50\% \pm 25\%$

The product must be turned off during storage. The switch must be in the "0" position. In case of longer storage, it should be connected to the power supply for 24 hours every 6 months to charge the batteries. The product cannot be stored when the batteries are discharged (the red LED on the panel is on).

The product is intended for installation and operation only in closed rooms with the following environmental conditions:

- temperature: 25°C (77°F) ± 10°C (18°F)
- humidity: 50% ± 25%
- atmospheric pressure 700 to 1060 hPa

3. Use and operation

3.1. Control panel (sample version of the touch panel LCD and membrane keyboard)

Touch panel LCD

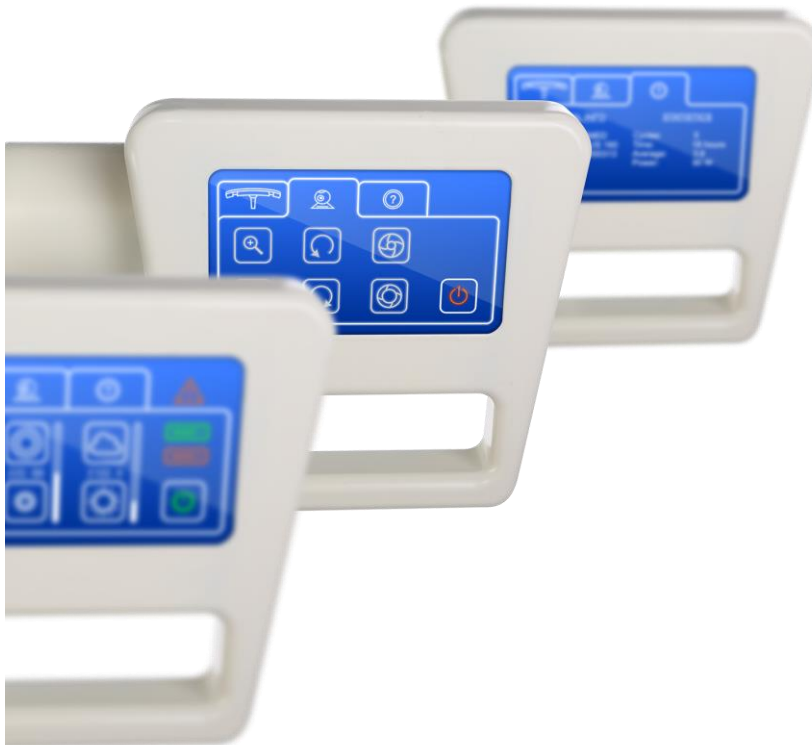

Lamp parameters control panel

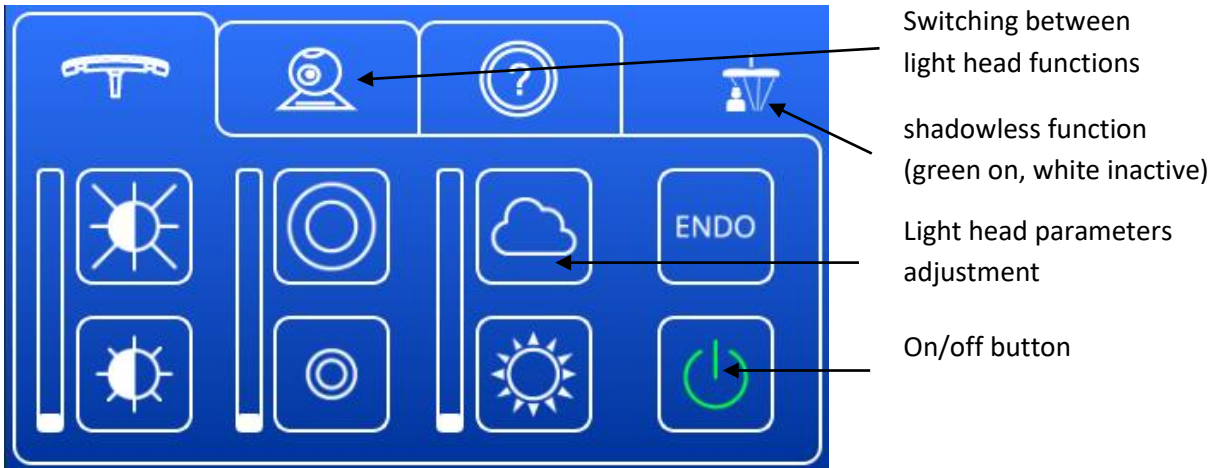

LCD touch panel with control of camera

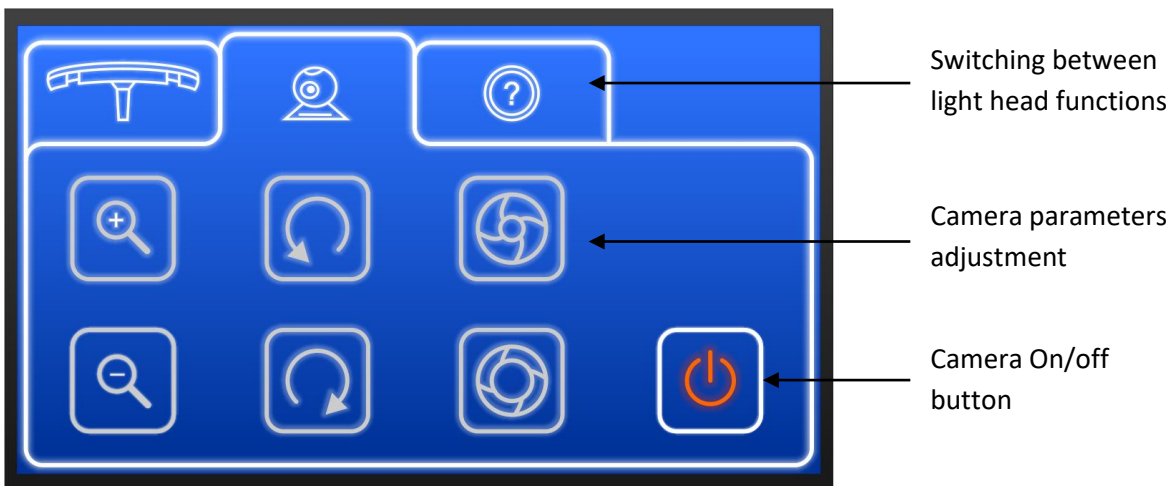

Functions can be adjusted from the panel:

- Zoom,
- Rotate the camera,
- Manual and auto iris

External wireless controller - for remote control and setting of lamp parameters:

- turning on and off,
- lighting intensity control,
- color temperature control,
- light field diameter adjustment,

- synchronized control of the parameters of both head lights.

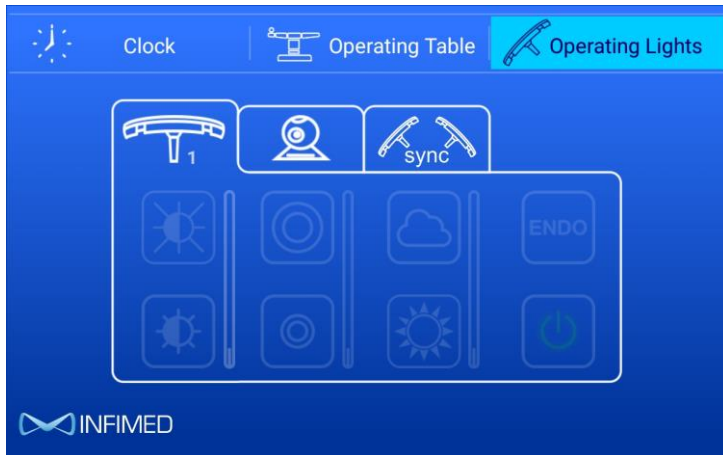

Membrane keyboard



Intelligent shadowless function (additional option)

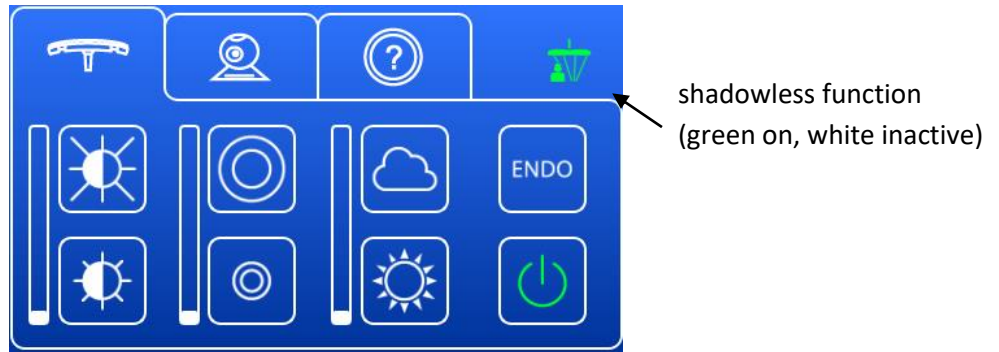

Activation by pressing the symbol in the upper right corner causes the activation of sensors detecting obstacles (e.g. surgeons' heads) - the operation is signaled in green. Sensors switch off the light panels covered with an obstacle above the operating field, and increase the remaining ones to maintain the lighting parameters in the operating field. Switching off is done by pressing the symbol again - white color signals the lack of operation.

Synchro function (additional option)

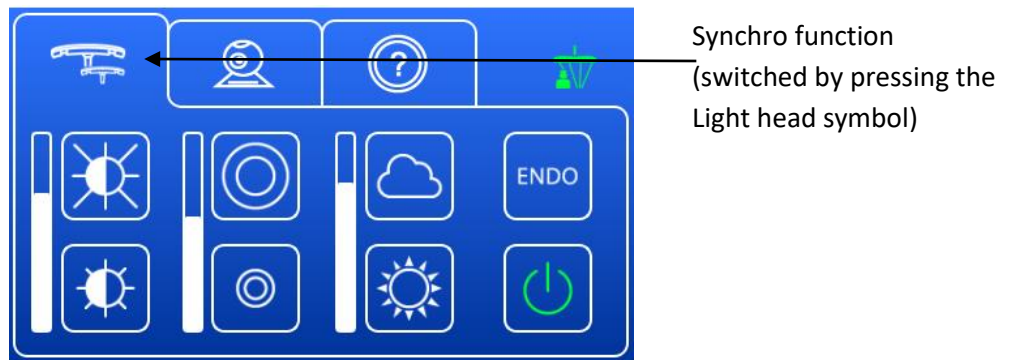

After pressing the light head symbol (upper left corner), the selection menu for single or group operation (the selected ones are marked in green) opens.

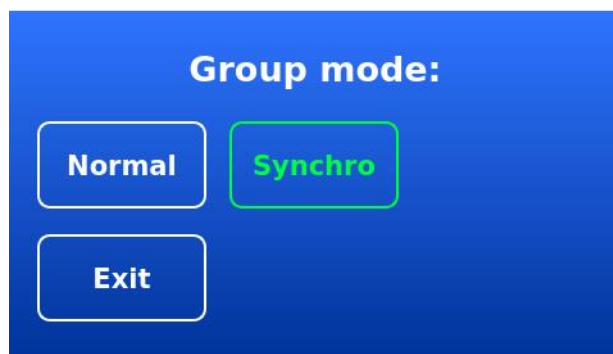

After activating the Synchro function, changing the parameters of any light head causes a change in both (operation signaled by the double light head icon).

To turn it off, select normal operation (operation signaled by a single light head icon).

3.2. Adjustment by regulation holder (additional option)

After the light head is turned on, it is possible to change the light parameters of the lamp using the sensor and the sterilized handle. Switching the functions is done by moving the hand under the sensor located in the light head, in the following order: intensity adjustment, field adjustment, color temperature adjustment, and the selected function is highlighted in blue.

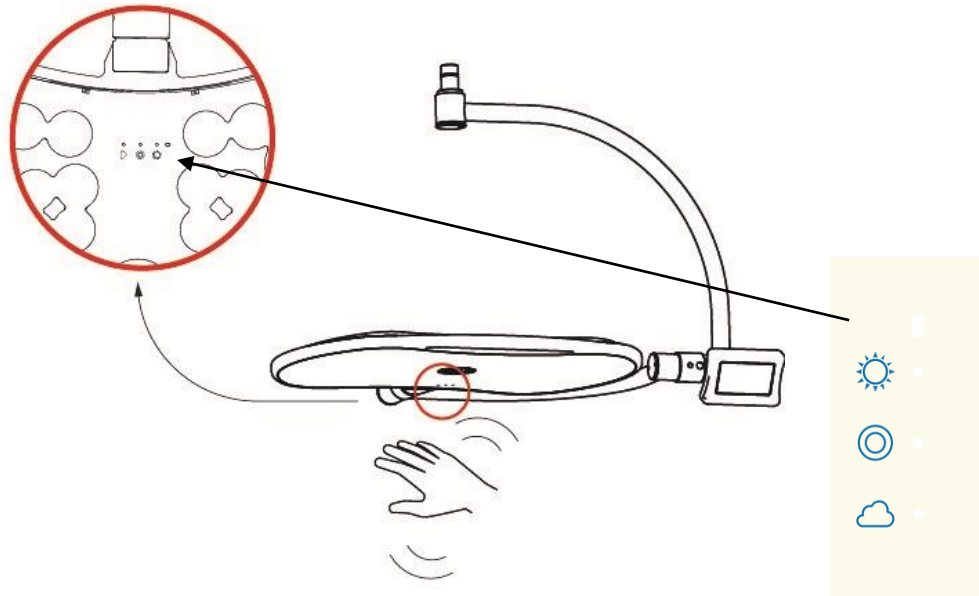

The light parameters of the selected lamp function can be realized optionally by turning the sterilizable adjustment handle to the right or left.

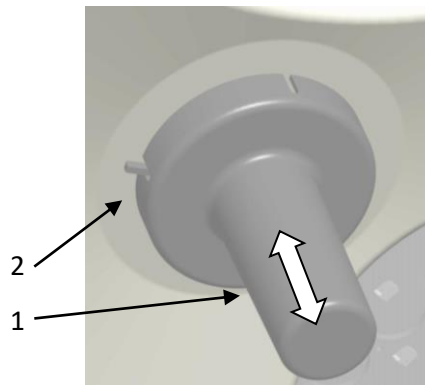

- In order to remove sterilized holder, please Press button no (2) and when keeping it pressed, please pull it down.
- in order to install the holder please slide it on guide rail (1) until it locks (2).

3.3. Positioning of the light heads depending on the spring arm

Ondal Arms

For positioning of the lamp head are used: sterilized regulation holder and holders placed on the edges of the lamp head. The height is adjustable by suspension arms. It is possible to adjust the tension arm. To reduce the tension (arm automatically rises) you should place control rod (located in the original packaging of the arm) into the hole and rotate it clockwise (+). When the force is too small (arm automatically drops) you should rotate control rod in a counter-clockwise (-).

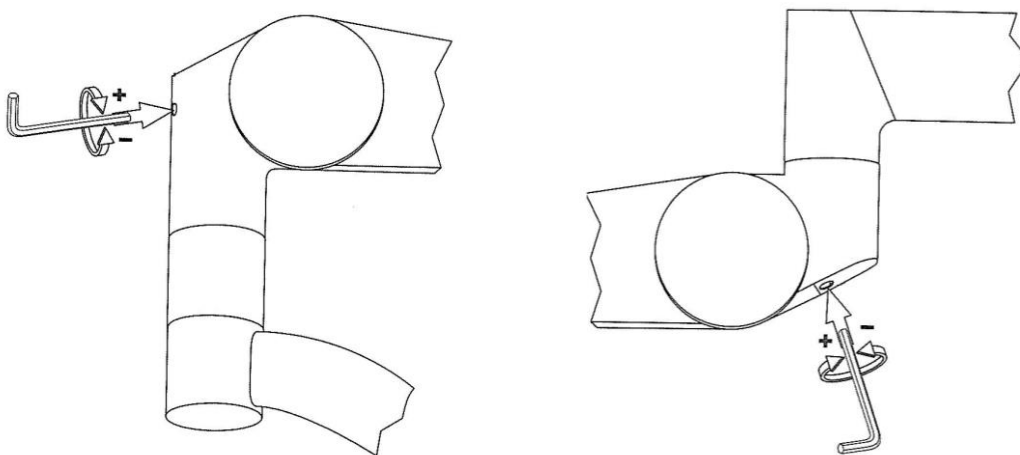

Method of adjusting the tension force and swing range of the Ondal spring arm

Liberec Arms

For positioning of the lamps head are used: sterilized regulation holder and holders placed in the edges of the lamp head. The height is adjustable by suspension arms. There is a possibility to adjust tension force of the arm. To limit tension force you should put iambus key into the slot (at the bottom of the arm) and turn in the direction indicated below. When the tension force is too small then iambus key should be turned in the other direction.

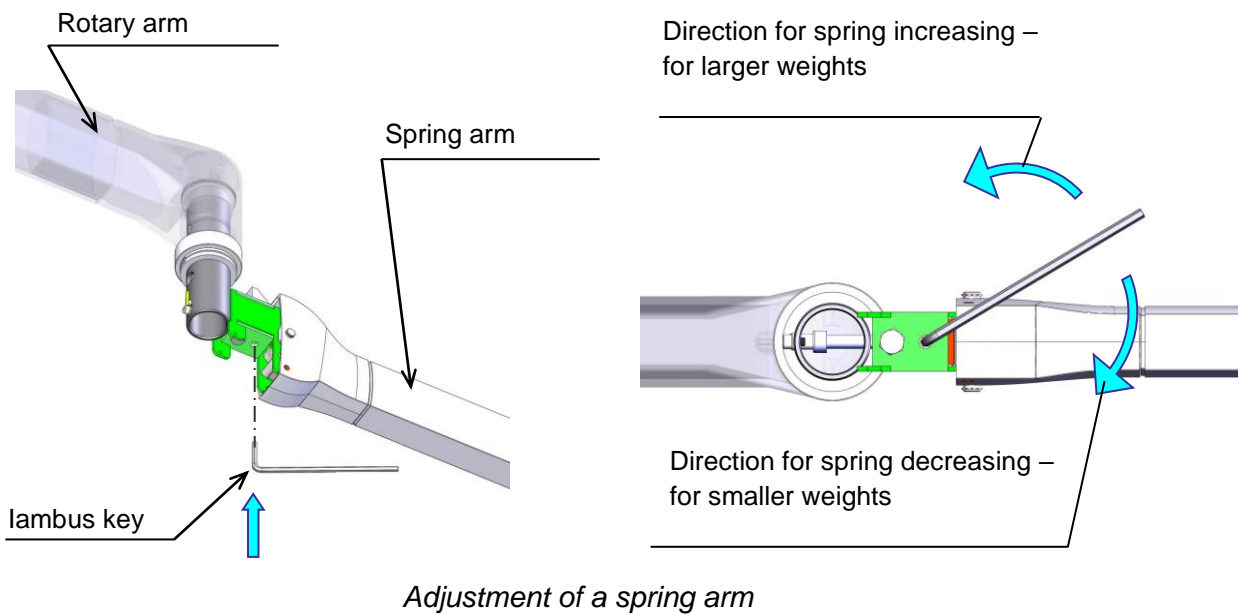
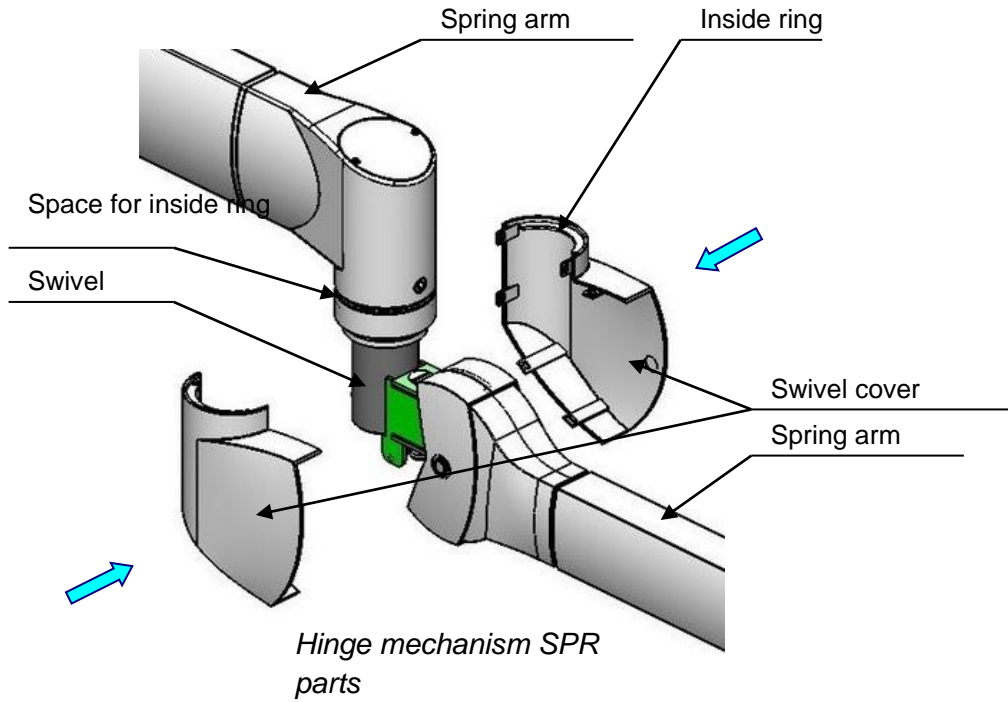

Do not adjust the function screw. It must be screwed in, it is not used for adjustment. 

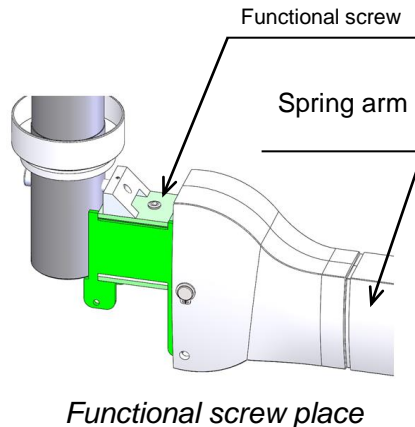

4. Mains supply and battery charging

Mains supply is indicated on the ceiling cover: green LED - operating main network, orange LED - operating emergency network.

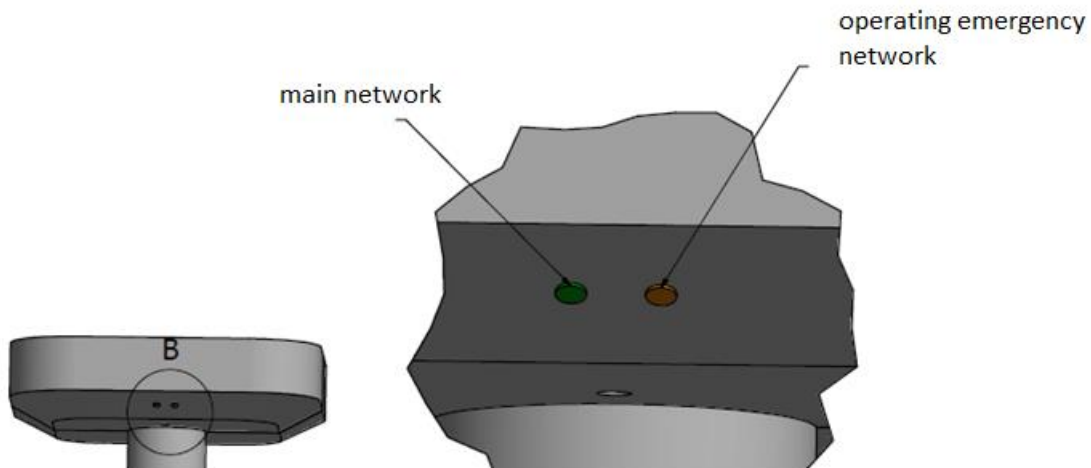

If the lamp is equipped with a charger which enables the charging of the lamp batteries, it should be connected to mains with supply parameters according to rating level. The charging system is started by inserting the appropriate end of the power cord in the socket located in the lamp casing, and putting the plug in the electric power socket, and toggling the switch located in the lamp casing from position 0 to 1.

Product cannot be used during the process of battery charging

On control panel or supply panel there is built in battery charge LED indicator. When only the green LED is lighted charging is not necessary. When the level of energy in the batteries falls, the additional LEDs will light and go out. The following indications are possible:

Green LED – batteries charged

Orange LED – battery charge on a level of 60% - **you may connect and charge**

Red LED – battery charge below a level of 30% - **charging of batteries is absolutely required**

The charging process may be started when the orange LED is lighted.

After connecting the power, the green LED will light. The batteries should be charged for a minimum of 6 hours. In the case the batteries are fully charged earlier the process will terminate automatically. In the case when the user terminates the charging process earlier, the LEDs corresponding to the given state of charging of the batteries will light.

The rated working time of batteries is about 3 hours. This period may be shortened depending on intensity of using of the lamp.

Do not store the lamp with discharged batteries.

When exchanging the batteries, you should always exchange the full set.

Overly frequent recharging of the batteries may shorten their lives.

Do not store the lamp with discharged batteries - if you do not use the product for more than a week, turn off the mains switch, and after a long period of non-use of the product, charge the batteries - at least once every six months.

5. Collision hazard

When moving the arms of the lamp you should pay attention to avoid mechanical collisions between arms or lamp heads, as well between other equipment in the operating room.

The lamp should be operated deliberately, with caution and full responsibility.

6. Assessment of correct operation

Before each first use during the given day the correct operation of the lamp should be assessed.

How to assess the correctness of functioning:

- Check the smoothness of movement by trying manually move the lamp
- Check if there are no mechanical backlash, by manual movement of lamps and arm system
- Check the functioning of the electronic system by the execution of all movements controlled from the control panel and sterilized regulating handle
- Check if the arms do not fall or rise automatically

If no inaccuracies or damage is detected during such a test and no worrying sounds were heard the lamp may be used. Otherwise, see the point on faults and defects.

In the case the lamp is not fully operational, that is, the parameters are not in accordance with the description in the user's manual, its use is not allowed. You should contact the supplier, maintenance service or the manufacturer. The use of a defective device may cause damage for which the user will be responsible, and for which the manufacturer is not responsibility.

7. Defects and faults

Defects and faults detected in the product by the operating personnel should be immediately reported to the person responsible for technical maintenance at the given station. This person, after checking the possible defect and its cause is obliged to contact the maintenance service or the manufacturer for a consultation and in order to obtain possible indications for further actions. The product which may not be safely used due to mechanical or electrical damage may not be used until repaired.

8. Cleaning and disinfecting

For the washing and disinfecting of the product you should use washing agents which do not contain active chlorine or oxygen. After disinfecting, the product should be washed with distilled water in order to remove water stains. Use a soft, sterile cloth for a thorough drying.



Before the disinfecting the power cord should be disconnected.

Do not use any compounds containing ingredients which destroy the structure of plastics for the washing of plastic elements.

Removable sterilized control handle is made of material resistant to high temperature sterilization conditions. Holder must be cleaned, disinfected and sterilized, either before first use or before each subsequent. Handle must be sterilized in an upright position, in an autoclave at a temperature to 134 degrees C for up to 5 minutes. Handles can be sterilized up to 100 times, after this period, holders must be replaced with new ones.

Diaphragm of LED lamps are made of polycarbonate, which can be cleaned using standard cleaning agents in solution at concentrations specified by the manufacturer. Do not wipe dry polycarbonate, use abrasive cleaners or use of an alcoholic strength of less than 20%. After cleaning, wipe the diaphragm using antistatic agent.

The list of disinfection agents is included in the Annex no. 1 to the user manual.

Failure to follow these requirements will cause the loss of the product warranty.

9. Maintenance and repairs

All repairs of the product are performed by an authorized maintenance service or a direct representative of the manufacturer. The user is not authorized to perform any modifications and repairs to the product without special training and authorization. After obtaining a written authorization from the manufacturer by the customer the manufacturer will provide all the information necessary to perform the repair.

In order to ensure a long and trouble-free operation of the lamp only original parts provided by the manufacturer should be used.

Since the product contains elements which may create an environmental hazard, the used parts have to be disposed in accordance with the environmental protection regulations.

In case of battery replacement, the manufacturer is required to reclaim the used batteries.

All the repairs and maintenance should be registered in the Card of Repairs attached to the User Manual of the product (Annex 2).

10. Technical inspection and periodical inspection

In order to ensure the proper technical condition of the product during its use, the user is obliged to submit the product to a periodical technical inspection. The inspection is performed by an authorized maintenance service or by a direct representative of the manufacturer. The inspection is performed at the user's cost.

Only a positive result of the inspection is a basis for further use of the product.

Each 12 months the following should be performed:

- detailed technical inspection
- functionality testing
- electric installation testing

In order to ensure the proper, safe operation of the lamp the user should check the technical condition of the device at least once every 6 months. This check should be performed as follows:

- perform all the functional movements of the arms checking the effectiveness of the brakes, swing arm tension forces, security of revolving connection
- check the status of the sterilized handle and operation of the fixation mechanism
- check the status of the lamp head - the state of the diaphragms, the functioning of control systems, etc.
- check the status of the earthing wire.

11. Removing of potential problems

- a) the lamp doesn't light
 - check the charge level of the batteries in the mobile version of light and the condition of the fuses,
 - check the condition of the lamp supply networks (operation indication on the ceiling cover: main - green LED and emergency – orange LED) - LEDs off - no power supply to both networks.

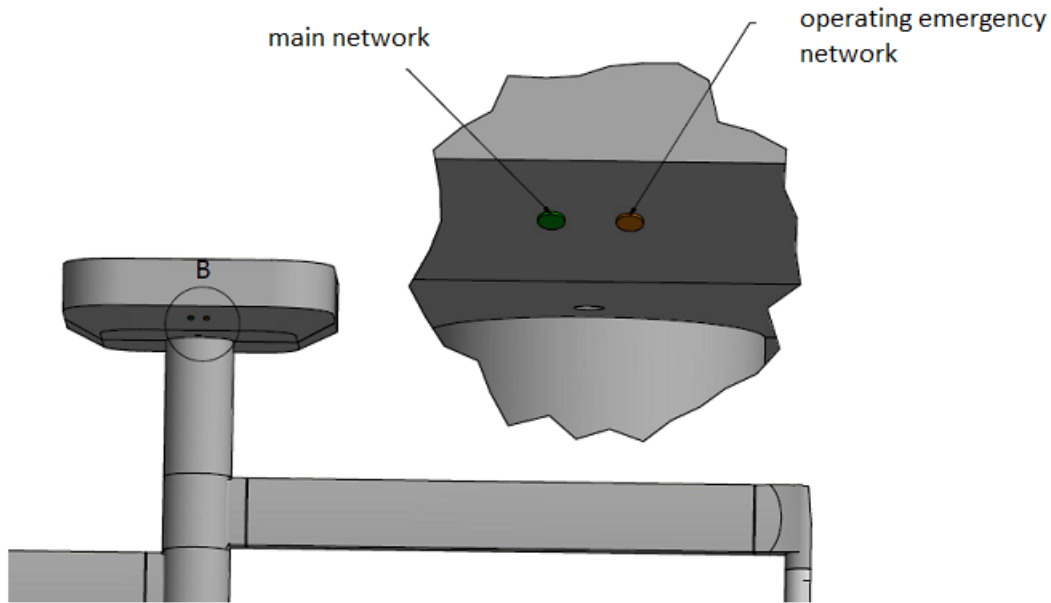

b) insecure fixation of sterilized handle

- replace the handle with the new one

In case of doubts contact the manufacturer in order to obtain the necessary help and explanations.

12. Product liquidation

The user, making decision of resigning from further product exploitation, is obliged to disinfect the product (the non-disinfected product according to rules concerning environmental protection is dangerous waste). There are three ways of proceedings:

1. Give the liquidation order to the producer.
2. Give the liquidation order to the company, having necessary attestation for liquidation or neutralization products in the way assuring protection of life, health of people and environmental protection.
3. Undertake liquidation itself, provided having the staff able to disassemble the product.

The rules for handling waste are specified in the Waste Act of December 14, 2012

13. Electromagnetic emissions

Medical devices operating lights **OL-01 and OL-02** should be used in electromagnetic environment specified below. The customer or the user of medical devices the **OL-01 and OL-02** should assure that they are used in such an environment.

Emission type	Classification	Explanations and guidances
emission RF CISPR 11	Group 1	Medical device operating lights OL-01 and OL-02 produce energy with radio frequency only for its internal function. Therefore, their RF emission is very low and is not likely to cause any interference in nearby electronic equipment.
emission RF CISPR 11	Class B	Medical device operating lights OL-01 and OL-02 are suitable for use in all establishments, including domestic establishments and those directly connected to the public low-voltage power supply network that supplies buildings used for domestic purposes.
Harmonic emission IEC 61000-3-2	Class A	
Voltage fluctuation, flickering IEC 61000-3-3	Complies	

Medical devices operating lights **OL-01 and OL-02** should be used in electromagnetic environment specified below. The customer or the user of medical devices the **OL-01 and OL-02** should assure that they are used in such an environment.

Immunity test	IEC 60601-1-2 Test level	Compliance level	Explanations and guidances
Electrostatic discharge (ESD) IEC 61000-4-2	± 6 kV contact ± 8 kV air	± 6 kV contact ± 8 kV air	In the location of OL-01 and OL-02 usage, the floor should be wooden, concrete or covered with ceramic tiles. If the floor is covered with a synthetic material, the relative humidity should be at least 30%.
Surge IEC 61000-4-5	± 1 kV between the conductors of the power line ± 2 kV between the power line conductor and the ground	± 1 kV between the conductors of the power line ± 2 kV between the power line conductor and the ground	The mains power supply and interference should be the same as in a typical commercial or hospital environment
Series of quick transitory stages IEC 61000-4-4	± 2 kV power supply lines ± 1 kV signal lines	± 2 kV power supply lines ± 1 kV signal lines	The mains power supply and interference should be the same as in a typical commercial or hospital environment
Voltage dips, short interruption and voltage variations on power supply input lines IEC 61000-4-11	< 5% U_T (>95% dip U_T) for 0.5 cycle 40% U_T (60% dip U_T) for 5 cycles 70% U_T (30% dip U_T) for 25 cycles < 5% U_T (>95% dip U_T) for 5 seconds	< 5% U_T (>95% dip U_T) for 0.5 cycle 40% U_T (60% dip U_T) for 5 cycles 70% U_T (30% dip U_T) for 25 cycles < 5% U_T (>95% dip U_T) for 5 seconds	The mains power supply and interference should be the same as in a typical commercial or hospital environment

NOTE U_T is the a.c. mains voltage prior to application of the test level

Medical devices operating lights **OL-01 and OL-02** should be used in electromagnetic environment specified below. The customer or the user of medical devices the **OL-01 and OL-02** should assure that they are used in such an environment.

Immunity test	IEC 60601-1-1 Test's level	Compliance level	Explanations and guidances
<p>Transmitted disturbances induced by fields with radio frequencies IEC 61000-4-6</p> <p>Electromagnetic field with radio frequency IEC 61000-4-3</p>	<p>3 Vrms 150 kHz to 80 MHz</p> <p>3 V/m 80 MHz to 2.5 GHz</p>	<p>3 Vrms</p> <p>3 V/m</p>	<p>Portable radio communication equipment should not be used at a distance shorter than the recommended separation distance, determined according to the correct formula depending on the frequency of the transmitter. This distance is the distance between the transmitter and any part of the medical device and/or its wiring.</p> <p>Recommended separating distance:</p> $d = 1,2\sqrt{P}$ $d = 1,2\sqrt{P} \quad 80 \text{ MHz to } 800 \text{ MHz}$ $d = 2,3\sqrt{P} \quad 800 \text{ MHz to } 2.5 \text{ GHz}$ <p>Where: <i>P</i> is the maximal output power of the transmitter in watts (W) according to the transmitter manufacturer and <i>d</i> is the recommended distance in meters (m).</p> <p>Field strengths from fixed RF transmitters, as determined by an electromagnetic site survey, ^a should be less than the compliance in each frequency range. ^b</p> <p>Interference may occur in the vicinity of equipment marked with following symbol:</p>  <p>The operating lamp should be observed to verify normal operation, if the operating lamp is used near to devices signed by this symbol.</p>

a Field strength from fixed transmitters, such as base stations for radio (cellular/cordless) telephones and land mobile radio, amateur radio, AM and FM radio broadcast and TV broadcast cannot be predicted theoretically with accuracy. To assess the electromagnetic environment due to fixed RF transmitters, an electromagnetic site survey should be considered in the place where OL-01 and OL-02 will be installed. If the measured field strength in the location in which medical device the operating light is used exceeds the applicable RF compliance level above, the operating light **OL-01 and OL-02** should be observed to verify normal operation. If abnormal performance is observed, additional measures may be necessary, such as reorienting or relocating medical device the operating light **OL-01 and OL-02** and/or using of additional precautionary measures.









b Over the frequency range 150 kHz to 80 MHz, field strength should be less than 3 V/m.

NOTES

These guidelines may not apply in all situations. Electromagnetic propagation is affected by absorption and reflection from structures, objects and people.

14. Labels

Labels on operating light NEXUS OL-01 and OL-02 :

1	<div data-bbox="331 344 1091 786" style="border: 1px solid black; padding: 10px;"> <p style="text-align: center;">Sposób ładowania akumulatorów</p> <p>Oznaczenie sygnalizacji</p> <ul style="list-style-type: none"> • Dioda zielona - akumulatory naładowane • Diody pomarańczowa - ok. 50% stan naładowania akumulatorów. • Diody czerwona - niski stan naładowania akumulatorów - bezwzględna konieczność podłączenia do ładowania. <p>Instrukcja ładowania</p> <p>Podłączyć przewód sieciowy do gniazda w podstawie lampy. Przełączyć przełącznik w położenie I. Proces ładowania sygnalizowany jest cyklicznym zapalaniem się diod stanu akumulatora. Czas pełnego naładowania min. 12 godzin. Po zakończeniu ładowania odłączyć przewód zasilający.</p> <p>W przypadku planowanego dłuższego nie używania lampy, należy w pełni naładować akumulator, a następnie przełączyć przełącznik w pozycję O. Przechowywanie lampy z rozładowanym akumulatorem grozi jego uszkodzeniem.</p> </div>	Safety instructions for rechargeable lamps
2	<div data-bbox="424 837 999 1234" style="border: 1px solid black; padding: 10px;"> <p style="text-align: center;">INFIMED NEXUS</p> <p style="text-align: right;"><small>INFIMED Sp. z o. o. ul. Kabaty 1, 34-300 Żywiec POLAND www.infimed.pl</small></p> <p>REF OL-01</p> <p>SN 0637353654</p> <p> 2024-07</p> <p>UDI (01)05904384698103(11)240722(21)0637353654</p> <p>MD    110W/100-260V~ 50-60Hz</p> </div>	Rating label NEXUS OL-01
3	<div data-bbox="424 1279 999 1675" style="border: 1px solid black; padding: 10px;"> <p style="text-align: center;">INFIMED NEXUS</p> <p style="text-align: right;"><small>INFIMED Sp. z o. o. ul. Kabaty 1, 34-300 Żywiec POLAND www.infimed.pl</small></p> <p>REF OL-02</p> <p>SN 0637353654</p> <p> 2024-07</p> <p>UDI (01)05904384698608(11)240722(21)0637353654</p> <p>MD    110W/100-260V~ 50-60Hz</p> </div>	Rating label NEXUS OL-02
4		Potential equalization socket

Rating label

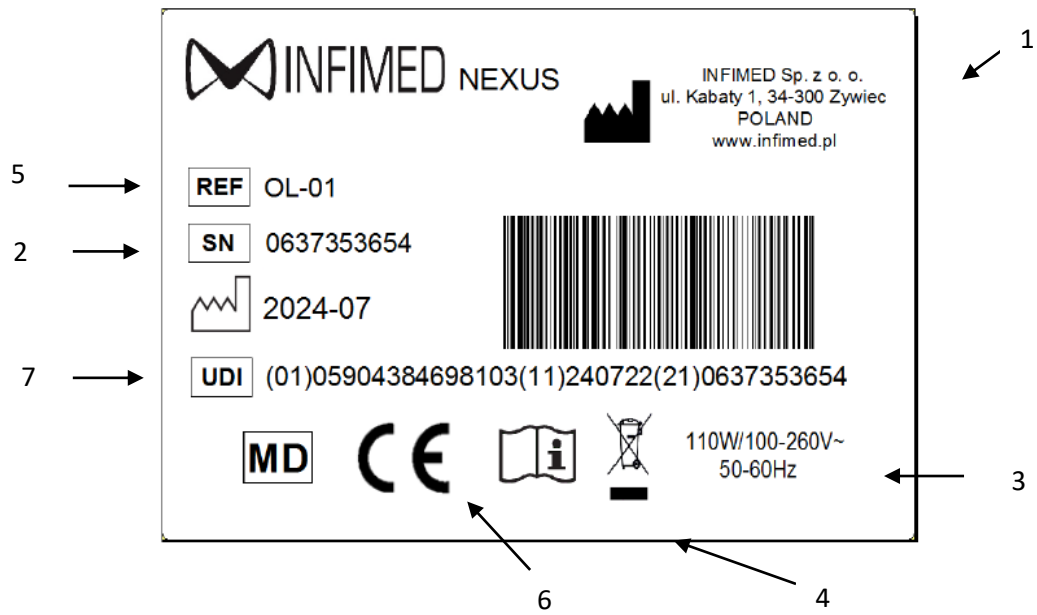

Description of designation:

1. Manufacturer's name, logo and address
2. Serial number
3. Power parameters, power consumption
4. Additional markings, e.g. application parts, tightness classes, etc
5. Product symbol
6. CE mark
7. Code UDI-DI-PI

UDI-DI-PI code explanation

NEXUS OL- 01

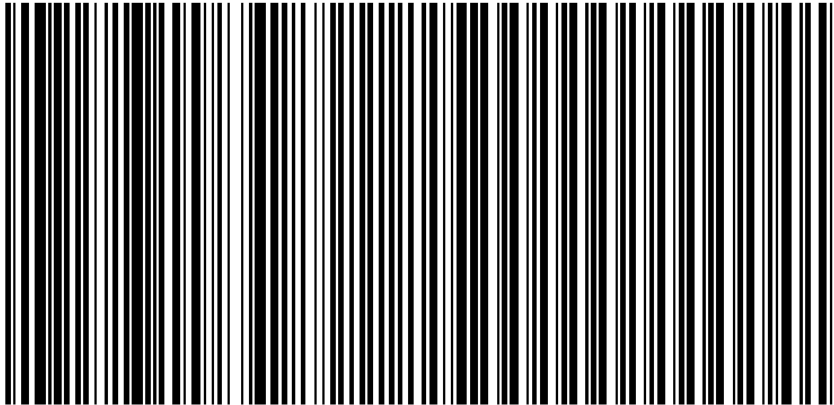

(01) 059043846981X7 (11) 000000 (21) XXXXXXXXXXXX

Prefix Krajowy Prefix firmy Cyfra kontrolna Data produkcji (YYMMDD) Numer seryjny
 Lampa operacyjna NEXUS



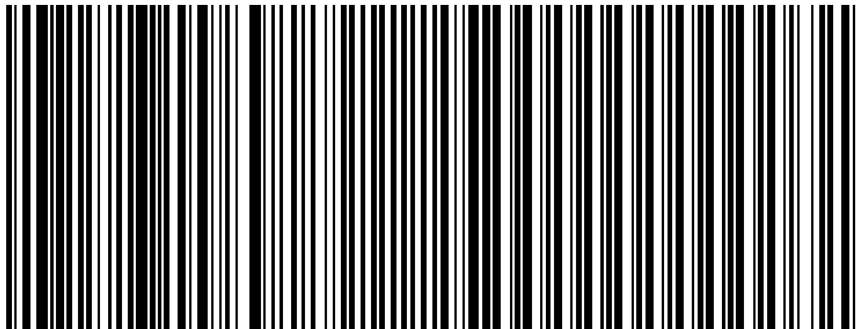







NEXUS OL- 02



(01) 059043846986X8 (11) 000000 (21) XXXXXXXXXXXX

Prefix Krajowy Prefix firmy Cyfra kontrolna Data produkcji (YYMMDD) Numer seryjny
 Lampa operacyjna NEXUS

Data presented on the label:

No.	Element:	Pictogram to use
1.	Company logo	
2.	Manufacturer's name and address	
3.	Name	Operating Lamp
4.	Part Number	
5.	CE mark – compliance of the product with the requirements of the MDR Regulation 2017/745	
6.	IP rating	IP-X4
7.	Serial Number	
8.	Production date	
9.	Read the User's Manual	
10.	Remark	
11.	Medical device	
12.	UDI code	

The manufacturer reserves the right to introduce changes in the light construction due to the use of new technological solutions which improve the product's functionality.

Annex no. 1

Agents recommended for cleaning and disinfection of surfaces of products and elements made of aluminum, epoxy coated steel and plastics.

AGENT	STEEL AND ALUMINUM	MATERIAL	DISTRIBUTOR/MANUFACTURER
MELISEPTOL	+	-	Aesculap-Chifa Sp.z o.o. ul. Tysiąclecia 14 64-300 Nowy Tomyśl tel: 061 4420100 fax: 061 4437505
DESPREJ	+	-	Bochemie PL Sp. z o.o. ul. Jana III Sobieskiego 11/E6 40-082 Katowice tel:+48694400019
TRICHLOROL	+	+	MEDILAB Sp. z o.o. ul. Niedźwiedzia 60 15-531 Białystok tel./fax: (85) 7479300 tel./fax: (85) 7479301
SURFANIOS PREMIUM	+	+	
NEOFORM MED RAPID	+	-	DR WEIGERT POLSKA Sp. z o.o. ul. Wybrzeże Gdyńskie 6D 01-531 Warszawa telefon: +48 (22) 6160223, 6160231
INCIDIN ACTIVE	+	+	Ecolab Sp. z o.o. ul. Opolska 114 31-323 Kraków Tel.: 48-12-2616 100 Fax.: 48-12-2616 101
INCIDIN FOAM	+	+	
TERRALIN PROTECT	+	+	Schulke Polska Sp. z o.o. ul. Rydygiera 8 01-793 Warszawa Tel : (022) 568-22-02 (022) 568-22-03 Fax: (022) 568-22-04
PERFORM	+	-	
DESCOCID	+	-	Antiseptica Dr. Hans-Joachim Molitor GmbH Carl-Friedrich-Gaus-Strasse 7, D-50259 Pulheim tel. +49 (0) 2234-98466-0 fax +49 (0) 2234-98466-11
ANTISEPTICA KOMBI SPRAY	+	-	
BIG SPRAY NEU	+	-	
VELOX SPRAY	+	+	Medisept Sp. z o.o. ul.Konopnica 193 c, 21-030 Motycz tel. +48815352222

Annex no. 2

Card of repairs and inspections of product

Operating light typeSerial noPurchase date

Inspection no	Inspection or repair date	Inspection type (annual, six-month)	Person performing inspection or repair	Sign of person performing inspection or repair	Comments concerning inspection or repair
1					
2					
3					
4					
5					
6					
7					
8					
9					
10					
11					
12					
13					
14					
15					
16					
17					
18					
19					
20					
21					
22					